

Design and Construction of an X-ray Diffraction Cell for Hydrate Studies at Elevated Pressures¹

Z. Huo,^{2,3} M. Eaton,^{2,4} K. T. Miller,² and E. D. Sloan^{2,5}

This work describes the setup and operation of an X-ray diffraction (XRD) cell for hydrate studies at elevated pressures (hereon we call it “high-pressure cell” for convenience). Most hydrate XRD measurements have been performed at low temperatures to ensure hydrate stability at atmospheric pressure. As a result, extrapolation has been required to determine hydrate volume at *in situ* conditions. With high pressure capabilities, however, this system can extend current structural knowledge without extrapolation, leading to less error in predictive modeling and a more accurate view of *in situ* hydrates. The cell has both low- and high-temperature capabilities, operating from 77 to 300 K using liquid nitrogen boil-off as a means of refrigeration, and can maintain pressures from 14 kPa to 7 MPa. Preliminary measurements of carbon dioxide hydrates at *in situ* conditions have been obtained and lattice parameters are comparable to those in the literature.

KEY WORDS: diffraction; hydrates; *in situ*; X-ray.

1. INTRODUCTION

Many earlier studies of hydrate structure using X-ray diffraction (XRD) or neutron diffraction have been performed at very low temperatures (as low as 7 K [1]) to ensure hydrate stability at atmospheric pressure

¹Paper presented at the Fifteenth Symposium on Thermophysical Properties, June 22–27, 2003, Boulder, Colorado, U.S.A.

²Center for Hydrate Research, Department of Chemical Engineering, Colorado School of Mines, Golden, Colorado 80401, U.S.A.

³Present address: Oilphase-DBR Schlumberger, 16223 Park Row, Suite 170, Houston, Texas 77084, U.S.A.

⁴Present address: Advanced Fuels Group, Energy Sciences and Technology Department, Brookhaven National Laboratory, Upton, New York 11973, U.S.A.

⁵To whom correspondence should be addressed. E-mail: esloan@mines.edu

[1–4]. While valid, these measurements may not accurately simulate *in situ* conditions, possibly leading to erroneous results when models are extrapolated to higher formation temperatures. Although neutron diffraction studies at elevated temperature and pressure exist [5,6], the availability of such equipment makes these measurements prohibitively expensive. Thus, a definitive *in situ* hydrate structural measurement using X-ray diffraction, a much less expensive alternative, is desirable.

In addition to the data extrapolation problems, measurements in this laboratory have experienced substantial condensation on the low-temperature cell window and sample surface. Not only did this interfere with the overall quality of the diffraction patterns obtained, but also limited the amount of structural information that could be acquired about the hydrates. To solve these problems, an XRD cell was custom designed to allow hydrate study at *in situ* conditions in this work.

2. CELL DESIGN

Several requirements need to be satisfied in order for such a cell to function properly:

- It must be able to contain a pressure of approximately 6.9 MPa to simulate *in situ* conditions.
- It must allow for the passage of cobalt X-radiation.
- It must contain enough sample surface area to give strong diffraction signals.

Beryllium (Be) is a natural choice to meet the above requirements as it is strong, transparent to X-rays, and easy to joint with support structures. A cylindrical Be tube is chosen as the basic construction to hold pressure. Another advantage of the cylindrical shape is that the X-rays will have constant attenuation at different angles.

To determine the dimensions of the beryllium cell, two factors had to be optimized: degree of X-ray attenuation and pressure holding capability. A thick wall will contain higher pressure, but would reduce the intensity of the X-ray signal substantially, and *vice versa*.

As shown in Fig. 1, the X-rays are attenuated twice by passing in and out of the cell through the tube wall (incoming X-ray and diffracted X-ray). Therefore, to have the X-ray counter, get at least 30% (an arbitrary value) of the intensity compared to an open sample, we need

$$\frac{I}{I_0} = e^{-\rho(\frac{L}{\rho})(2x)} = 0.3$$

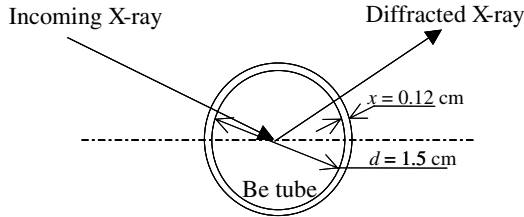

Fig. 1. Be tube and X-ray path.

where I is the X-ray beam intensity received by the counter with the beryllium tube, I_0 is the intensity with an open sample, ρ is the density, and (μ/ρ) is the mass absorption coefficient of Be; $2x$ is the total penetration thickness through Be by the X-rays. According to Cullity [7], the density of Be is $1.85 \text{ g} \cdot \text{cm}^{-3}$ and the mass absorption coefficient is $2.42 \text{ cm}^2 \cdot \text{g}^{-1}$ for cobalt radiation [8]. Based on these values, we get the maximum wall thickness allowed for the Be tube is 0.13 cm (x). In the design, we used 0.12 cm beryllium to ensure strong diffracted X-rays.

The desired experimental condition was to have stable methane hydrates at 277.15 K , a typical seafloor temperature. This requires that the minimum operation pressure in the cell should be 3.86 MPa [9]. However, to ensure high conversion and to keep hydrates stable over minor temperature fluctuations, greater pressures are required. Here we arbitrarily choose 6.9 MPa as the maximum working pressure.

Many factors, such as micro-defects within the beryllium and the strength of the joints between the beryllium and supporting materials affect the overall strength of the design. To ensure safe operation, a safety factor of 5 was applied based on expert recommendations. Thus a bursting pressure of the beryllium tube, 34.5 MPa , was determined to be the targeted design.

Assuming that the tube can be approximated as a thin-wall tube, the maximum pressure can be calculated as

$$p = \frac{\sigma x}{d}$$

where p is the maximum pressure a thin-wall tube can stand, σ is the yield tensile strength, x is the wall thickness, and d is the radius of the tube [10]. With a knowledge of the maximum pressure, yield tensile strength, and the wall thickness known, the radius of the tube is determined to be 1.41 cm .

For manufacturing purposes, we chose 1.5 cm as the inner diameter of the Be tube. This provides a safety factor of 4.7 when the working pressure is 6.9 MPa .

3. CELL ASSEMBLY

In order to secure the Be tube to the Siemens D-500 diffractometer, a stainless steel housing was constructed to support the tube and also to facilitate the Be tube attachment. Three flanges were attached to the tube (see Fig. 2): flange 1 fit the tube to the goniometer face of the diffractometer as well as accepted an inlet gas feed, flange 2 was placed at the opposite end of the tube to serve as a mounting plate for the pressure-sealing flange, and flange 3 allowed for the containment of pressure as well as temperature monitoring via a thermocouple feedthrough. An O-ring groove was machined into flange 2 to ensure effective seal against elevated pressures. Flanges 1 and 2 were attached together via a stainless steel tube (not shown individually) with two 65° windows to allow for X-rays to pass through the beryllium tube (see Fig. 3).

A sample holder containing the sample is inserted into the beryllium tube/stainless steel housing, and held in place by several pins and plungers. This system was used to ensure precise alignment of the sample surface each time a new sample was mounted. An overall view of the assembly can be seen in Fig. 3.

In this system, the temperature is regulated by passing gaseous nitrogen (from liquid nitrogen boil-off) over the beryllium enclosure. A constant flow of the dry, gaseous nitrogen partially prevented condensation on the outside of the beryllium tube, even at lower temperatures. A proportional-integral-derivative (PID) controller, attached to the thermocouple on flange 3, regulates the heating of the boil-off. Temperature control of the cell can be maintained from 78 to 300 K, with a fluctuation of approximately ± 1.5 K.

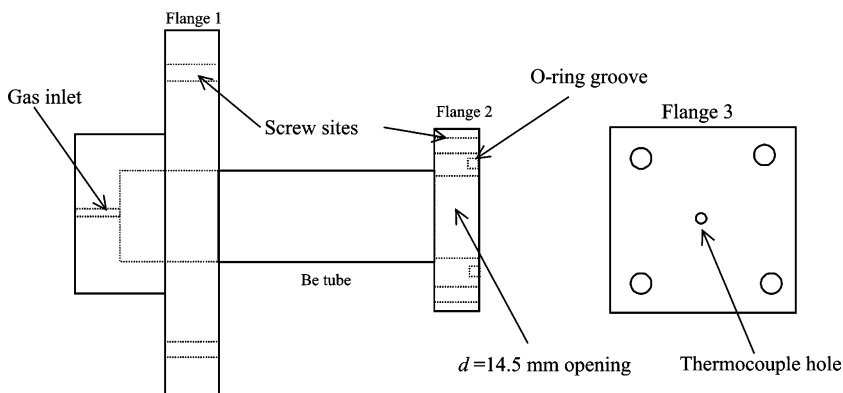

Fig. 2. Be tube with supporting materials.

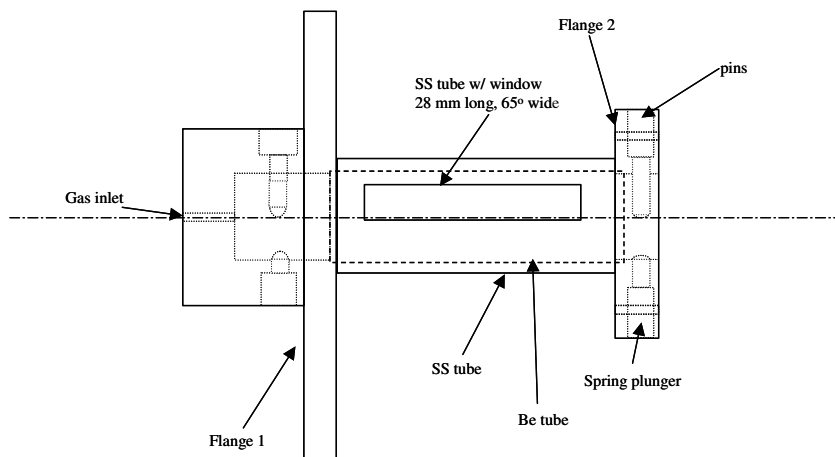

Fig. 3. Overall assembly of the cell.

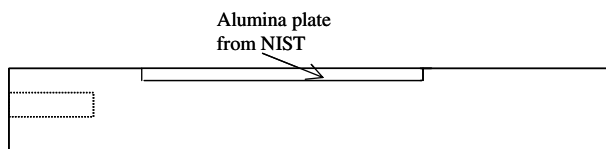

Fig. 4. Standard calibration material.

4. CALIBRATION AND ALIGNMENT

To ensure proper operation and correct alignment of the newly installed system, extensive calibration was required. A standard sample obtained from the National Institute of Standards and Technology (NIST), known as SRM 1976, was used for the entire calibration. SRM 1976 is a flat plate approximately $5\text{ cm} \times 5\text{ cm}$ made from alumina with peak intensities given by NIST and peak positions provided by the International Center for Diffraction Data (ICDD, 82-1467). For proper alignment in a diffraction system, both intensities and peak positions in a given pattern should match those of a known sample's pattern. To compare the pattern of SRM 1976 from the high-pressure cell to those provided by NIST, the sample holder was retrofitted with a $1.4\text{ cm} \times 4\text{ cm}$ piece of SRM 1976. Figure 4 shows the design of the sample holder.

After substantial adjustments, alignment and calibration of the new system were achieved. For reproducibility, the diffraction work was performed three times on the sample as shown in Fig. 5a. As shown in Fig. 5b the peak position difference between the high-pressure cell results

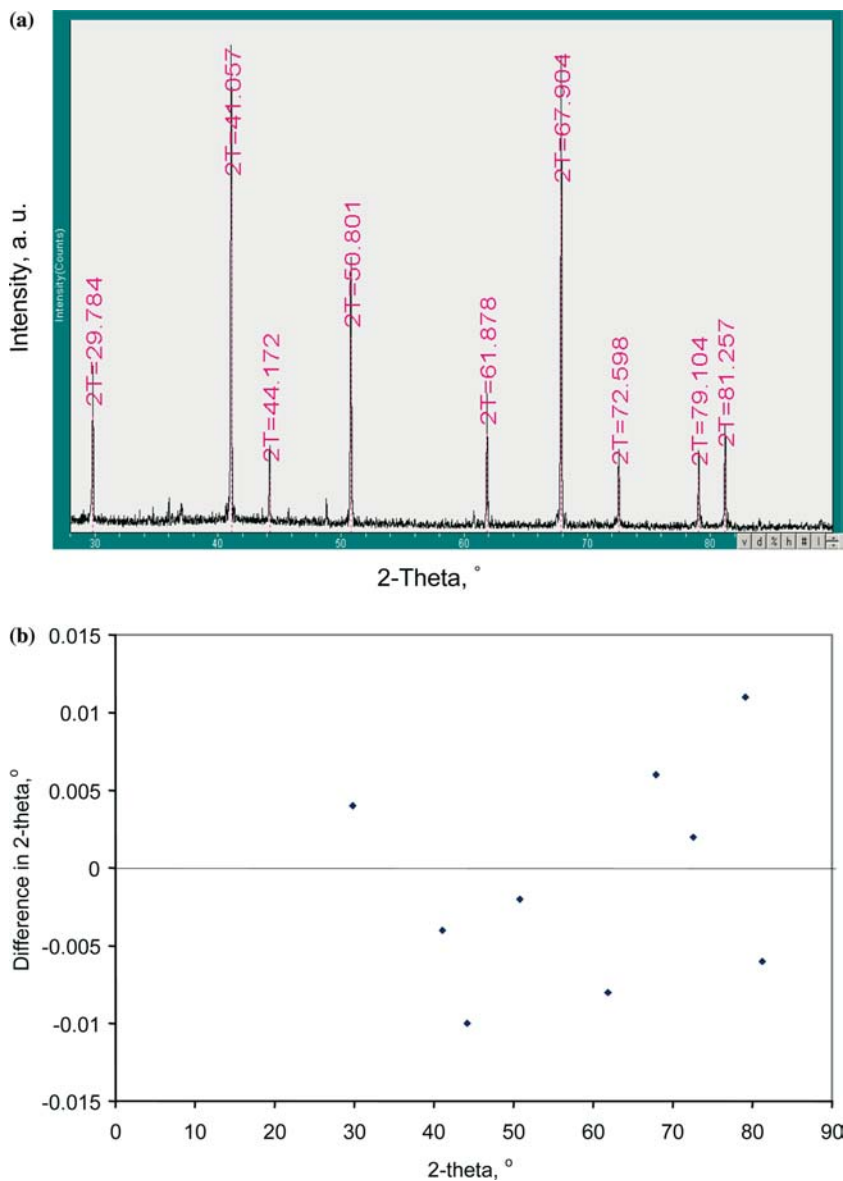

Fig. 5. (a) Pattern obtained for SRM 1976 in high-pressure cell. (b) Difference between ICDD data and new system measurements on SRM 1976 less than 0.01° .

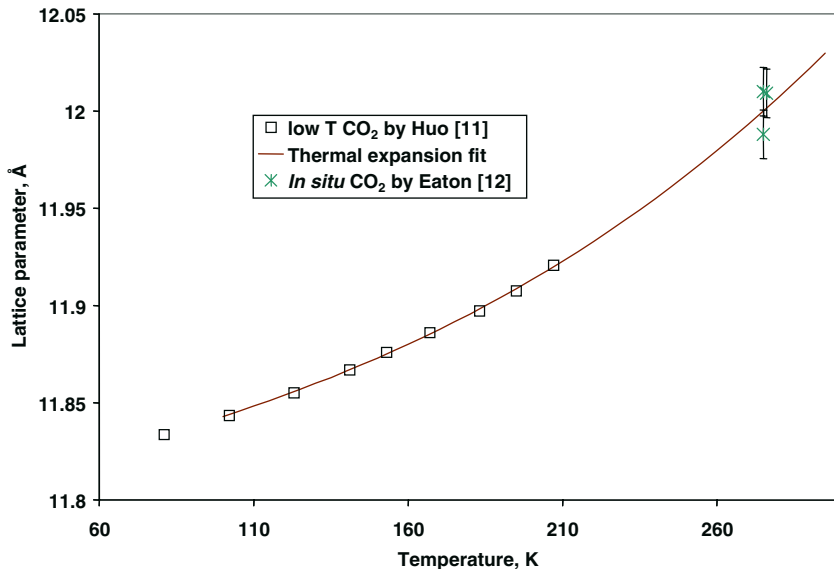

Fig. 6. *In situ* measurements with high-pressure cell agreed well with low temperature thermal expansion measurement.

and those provided by ICDD were less than 0.01° . This difference is equivalent to 0.02% in hydrate lattice parameter measurements.

5. PRELIMINARY MEASUREMENTS

Upon calibration, CO₂ hydrates were successfully formed in the cell at 2.91 MPa and at both 275 and 276 K, and lattice parameters were measured and values were compared to extrapolations from low temperature measurements. As shown in Fig. 6, the high-pressure data taken at 275 and 276 K agree very well with the low temperature thermal expansivity measurements [11,12]. This demonstrates that the high-pressure cell is capable of measuring *in situ* hydrate properties.

6. CONCLUSIONS

A diffraction cell with high-pressure and low-temperature capabilities for conventional XRD was designed. The central part of this design is a Be tube with 1.4 cm I.D. and 0.12 cm wall thickness. The working pressure of the Be tube was 6.9 MPa with a safety factor of 4.7. Special supporting structures such as an alignment tool and sample holder were also designed

to accommodate the special shape of the cell. The high-pressure low-temperature cell was aligned and calibrated. The average peak position difference between actual measurements and ICDD values was found to be less than 0.01° . CO_2 hydrate were successfully formed in the high-pressure cell at 275 and 276 K. *In situ* lattice parameters agreed well with low-temperature measurements.

ACKNOWLEDGMENTS

The authors wish to thank our industrial consortium members: BP, Chevron-Texaco, Department of Energy, Halliburton, Phillips, and Unocal for their financial support of this work. The authors thank Chevron for their donation of the Siemens D-500 diffractometer. Additionally, the authors would like to thank Brushwellman Electrofusion Products for manufacturing of the Be cell. We also thank Mr. Ivan Getting at the University of Colorado at Boulder, and Dr. David Olson at the Colorado School of Mines for their help in designing the Be tube.

REFERENCES

1. C. J. Rawn, A. J. Rondinone, B. C. Chakoumakos, S. L. Marshall, L. A. Stern, S. Circone, S. H. Kirby, C. Y. Jones, B. H. Toby, and Y. Ishii, *Proc. Fourth Int. Conf. Gas Hydrates*, Yokohama (2002), pp. 595–598.
2. M. Von Stackelberg and H. R. Muller, *Feste Gashydrate II*, *Z. Electrochem.* **58**:25 (1954).
3. J. S. Tse and W. R. McKinnon, *J. Phys. Chem.* **91**:4188 (1987).
4. Z. Huo, K. T. Miller, and E. D. Sloan, *Proc. Fourth Int. Conf. Gas Hydrates*, Yokohama (2002), pp. 697–700.
5. B. Chazalon and W. F. Kuhs, *J. Chem. Phys.* **117**:1 (2002).
6. D. K. Staykova, T. Hansen, A. N. Salamatina, and W. F. Kuhs, *Proc. Fourth Int. Conf. Gas Hydrates*, Yokohama (2002), pp. 537–542.
7. B. D. Cullity, *Elements of X-ray Diffraction* (Addison-Wesley, Reading Massachusetts, 1967), p. 466.
8. Automation Creation Inc., Matweb.com (2002).
9. A. Ballard, Ph. D. thesis (Colorado School of Mines, Golden, Colorado, 2002).
10. J. M. Gere, *Mechanics of Materials*, 5th Ed. (Brooks/Cole Pub. Co., 2000).
11. Z. Huo, Ph. D. thesis (Colorado School of Mines, Golden, Colorado, 2002).
12. M. Eaton, M. S. thesis (Colorado School of Mines, Golden, Colorado, 2003).